



**BALTIMORE
AIRCOIL COMPANY**



PF-64M Separators

INSTALLATION, OPERATING & MAINTENANCE

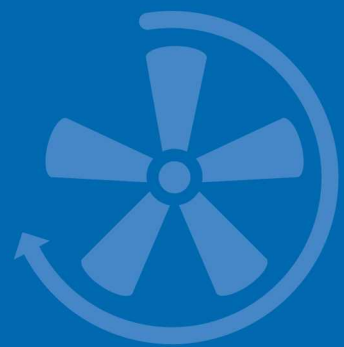
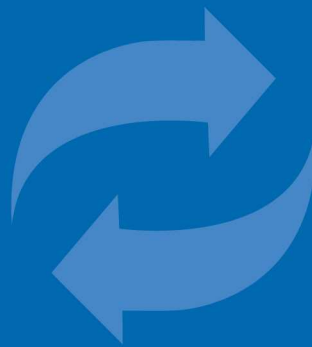



Recommended maintenance and monitoring programme

Baltimore Aircoil Company is the right choice when it comes to having a more efficient, safe, and effective system.

The PF-64M series separators are designed to assist in eliminating expensive down-time, reducing operating cost, chemical usage, wear and tear on equipment and maintenance. With many years of combined filtration experience, BAC engineers can find a solution to a wide variety of cooling tower application filtration problems. Following the guidelines listed in this manual will help to insure the safety of all personnel who maintain the PF-64M series separators. If there are any questions on the procedures or performance of the PF-64M series separators your local BAC representative. Name, e-mail and phone number can be found on the website www.BACservice.eu

Do Not operate the separator until all questions about operating procedures are answered by a qualified representative. This manual covers recommended procedures for installation and anchoring, start-up and shut down, and safety and maintenance.

All recommendations are minimums. The environment/operating conditions in which the separator unit is installed will dictate the frequency of scheduled maintenance. Maintaining your PF-64M series separators will assure a long trouble free life.

Table of contents

INSTALLATION, OPERATING & MAINTENANCE INSTRUCTIONS



2	Construction details	4
	PF-64M Separator	4
3	General information	5
	Safety precautions	5
	Disposal requirements	6
	Modifications by others	6
4	Receiving and installation	7
	Receiving equipment	7
	Design criteria	7
	Support and lifting	8
	Installation and anchoring	8
	Piping interface connections	8
	Separator requirements	9
	Electrical controls	9
	Wiring requirements	10
5	Maintenance procedures	11
	Operating conditions	11
	General maintenance procedures	11
	Purge requirements	12
	Pump requirements	14
6	Start-Up and Shutdown	16
	Start-up	16
	Shutdown	17
7	Cold weather operations	18
	About cold weather operation	18
8	Comprehensive maintenance	19
	About comprehensive maintenance	19
9	Fluid treatment	20
	About fluid treatment	20
	Biological control	20
	Chemical treatment	20
10	Further Assistance & Information	21
	The service expert for BAC equipment	21
	More information	21

PF-64M CONSTRUCTION DETAILS

PF-64M Separator

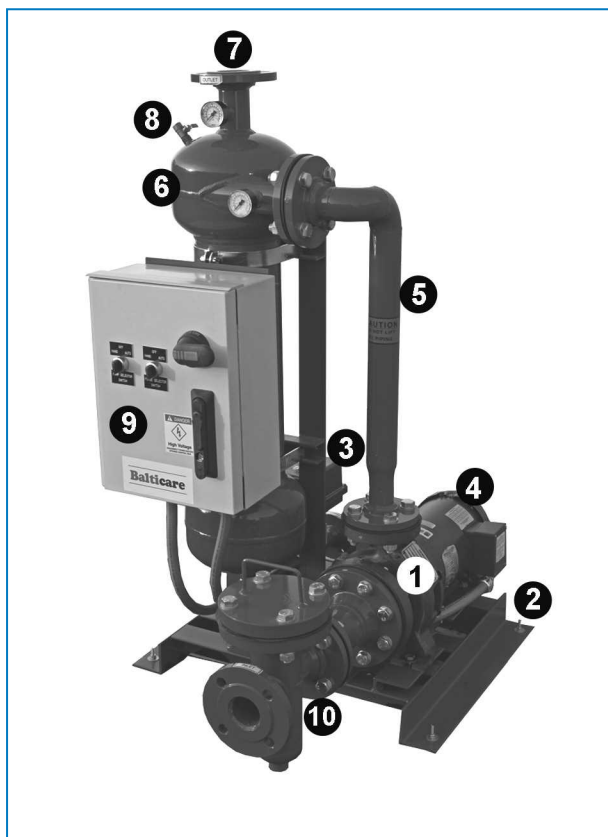

1. Inlet
2. Coated steel skid
3. Auto purge valve
4. Pump and motor assembly
5. Carbon steel face piping
6. Pressure gauge
7. Outlet
8. Manual air vent valve
9. Control cabinet
10. Pre-strainer (optional)

Safety precautions

All electrical, mechanical and rotating machinery constitutes a potential hazard, particularly for those not familiar with its design, construction and operation. Accordingly, adequate safeguards (including use of protective enclosures where necessary) should be taken with this equipment both to safeguard the public (including minors) from injury and to prevent damage to the equipment, its associated system and the premises. If there is doubt about safe and proper rigging, installation, operation or maintenance procedures, contact the equipment manufacturer or his representative for advice.

When working on operating equipment, be aware that some parts may have an elevated temperature. Any operations on elevated level have to be executed with extra care to prevent accidents.

AUTHORIZED PERSONNEL

The operation, maintenance and repair of this equipment should be undertaken only by personnel authorized and qualified to do so. All such personnel should be thoroughly familiar with the equipment, the associated systems and controls and the procedures set forth in this and other relevant manuals. Proper care, personal protective equipment, procedures and tools must be used in handling, lifting, installing, operating, maintaining and repairing this equipment to prevent personal injury and/or property damage. Personnel must use personal protective equipment where necessary (gloves, ear plugs, etc...)

ELECTRICAL SAFETY

All electrical components associated with this equipment should be installed with a lockable disconnect switch located within sight of the equipment.

In the event of multiple components, these can be installed after a single disconnect switch but multiple switches or a combination thereof are also allowed.

No service work should be performed on or near electrical components unless adequate safety measures are taken. These include, but are not limited to the following:

- Isolate the component electrically
- Lock the isolation switch in order to prevent unintentional restart
- Measure that no electrical voltage is present any more
- If parts of the installation remain energized, make sure to properly demarcate these in order to avoid confusion

Fan motor terminals and connections may have residual voltage after unit shut-down. Wait five minutes after disconnecting the voltage at all poles before opening the fan motor terminal box.

LOCAL REGULATIONS

Installation and operation of cooling equipment may be subject to local regulations, such as establishment of risk analysis. Ensure regulatory requirements are consistently met.



Disposal requirements

Dismantling of the unit and treatment of refrigerants (if applicable), oil and other parts must be done with respect to the environment whilst protecting workers from potential risks related to exposure to harmful substances. National and regional legislation for material disposal and protection of workers should be taken into account with regard to:

- Appropriate handling of construction and maintenance materials when dismantling the unit. In particular when dealing with materials that contain harmful substances, such as asbestos or carcinogenic substances.
- Appropriate disposal of the construction and maintenance materials and components such as steel, plastics, refrigerants and waste water according to local and national requirements for waste management, recycling and disposal.

Modifications by others

Whenever modifications or changes are made by others to the BAC equipment without written permission of BAC, the party who has done the modification becomes responsible for all consequences of this change and BAC declines all liability for the product.

4

PF-64M RECEIVING AND INSTALLATION

Receiving equipment

Before accepting the separator equipment and prior to signing the bill of lading, all equipment should be checked thoroughly for any shipping damage. Make sure that all required equipment noted on the bill of lading is received. Refer to "Construction Details" on page 1 and the below table for components to be inspected upon receiving.

Receiving / Inspection
Separator vessel
Control panel
Inlet/Outlet gauges
Interconnecting piping
Isolation valves
Manual air vent valve
Pump & Motor
Auto purge valve
Pre-strainer (optional)

Check the model and serial number against the packing slip. Serial and model numbers can be found on a nameplate inside the control cabinet (automatic unit).

Design criteria

The BAC standard PF-64M series separator is designed for use in closed circuit or open process liquid applications. Standard equipment design is 1050 kPa @ 65°C (higher design pressures and temperatures are available). The PF-64M series separator will remove suspended solids with a specific gravity of 1.2 or higher down to 45 micron/325 mesh.

The PF-64M series separator packages utilize a PF-61 series separator. Standard units are equipped with motor controls, inlet and outlet gauges, pump and motor, carbon steel interconnecting piping, manual air vent valve, coated steel skid and automatic purge. Pump pre-strainer and removable dome are optional.

 Never install the PF-64M series separator in an application where the system pressure exceeds the separator package design pressure.



Support and lifting

The PF-64M series separators can be lifted from the bottom of the separator skid with the skid fully supported. If the unit is hoisted, lifting straps must be placed under the bottom of the filter skid and should not come in contact with the separator components.

Installation and anchoring

The PF-64M series separator is designed for slip stream use on non-pressurized open sump or pressurized closed system applications. The PF-64M series separators should be located as close to the sump or interface piping as possible and never installed in full flow system piping.

The PF-64M series separators can be rigidly anchored to the floor using 12 mm anchor bolts. Refer to the certified drawing for location of anchor holes.

The PF-64M series separators should not be installed above the process liquid operating level. Make sure that the pump and all piping between sump outlet and separator pump inlet connections are below operating level.

Piping interface connections

The filter piping should be installed as follows:

1. Installation of interconnecting piping
 - When mating interconnecting fittings to the filter unit make sure that filter components are securely held in place so no damage or leaks occur.
 - If welding or soldering mating flanges or fittings make sure not to overheat filter components. Overheating filter components can cause damage or leaks.
 - If welding **DO NOT** use the filter or its components as a ground.
2. For piping connections sizes refer to the certified drawing and/or specific data sheet.
3. **Do not** reduce the pipe sizes below the separator connection diameter; the pipe sizes are minimums. It is recommended to size piping diameter to maintain flow speed below 1.5 m/s for suction side (between cooling tower outlet and separator inlet) and 2 m/s for the separator discharge side (outlet). If long runs, excess fittings, or lifts are necessary, it is recommended to further enlarge the pipe diameter in order to reduce friction loss. Total pressure drop in the piping between the separator and the unit (suction and discharge) should be limited to 90 kPa maximum.
4. Never reduce the waste line; this can restrict the flow of the purge cycle and reduce efficiency.
5. Run an influent line from the system sump to the pump or pre-strainer labelled "INLET". A service valve and union should be installed in this line near the separator. Refer to certified drawings.



If the separator inlet connection and/or piping are located above the process liquid operating level (sump operating level), a foot or check valve must be installed below the water level to prevent loss of pump prime. BAC however does not recommend this solution.

6. Run an effluent line from the separator return labelled "OUTLET" back to the system sump. A service valve and union should be installed in this line near the separator. Refer to certified drawings.
7. Run a waste line from the separator purge outlet labelled "WASTE" to the nearest sewer drain. A union should be installed in this line near the separator. Refer to certified drawings.
8. In case one separator is serving several cooling towers or evaporative condensers in parallel, the units must mandatory be equalized to prevent operating issues, overflow, air suction.



CAUTION

Do not put any type of valve in the waste line!



Always follow local, country, state or other government authorities' requirements for piping hook-ups.

Separator requirements

1. The PF-64M series separators are equipped with a pump designed to maintain proper flows through the separator system. Standard units are equipped with a pump to match the required separator system flow (l/s)@ 230 kPa of head. (refer to data sheet for exact pump head for specific model) BAC separators are designed to operate within a specified range; 27 to 63 kPa pressure drop across the separator is recommended. Some installations may require that a throttling valve be installed in the outlet line to regulate the flow or the pump be altered (lower/higher discharge head) to maintain proper flows.
2. The separator should be installed to merge with the natural flow of the system, never against it. A straight run of 5 to 6 pipe diameters up and down stream of the separator is recommended to reduce turbulence.
3. The minimum inlet pressure should be at least equal to the pressure loss anticipated through the separator plus the systems downstream pressure requirements. Pipe sizes must be large enough to maintain proper flow. Refer to the individual data sheets and certified drawings. It is important to understand that the selection of a separator is based on the flow rate through the separator (approx. 3 m/sec.) and not the separator pipe size (connections).
4. Dry weight, operating weight and volume: refer to individual data sheets for specific operation.

Electrical controls

The PF-64M series separators can be supplied in a number of configurations and voltages. Standard voltages include 400V/3ph/50Hz (additional alternate voltages are available). Primary voltage will be reduced to 120V control voltage. Control components will vary depending on separator configuration and options.

1. Standard separator units are equipped with a IP65 control cabinet containing a locking combination on/off disconnect switch with motor circuit protection (MCP), control transformer, HOA switch and motor contactor.
2. Automatic purge includes an adjustable purge timer, purge HOA switch and electric valve actuator.



Wiring requirements

Install circuit breaker between the closest branch distribution panel and the control panel. (Refer to specific unit data sheet/motor nameplate for amperage draw by motor horsepower.) The control cabinet is pre-wired and includes a door disconnect switch with overload and short circuit protection.

Automatic Purge Unit: The electric purge actuator will draw approximately 1 additional amp.



1. All incoming power supply lines must be connected to the door disconnect when provided.
2. Refer to motor nameplate for model not listed or for other voltage/Hz.



CAUTION

Always follow local authorities' requirements for electrical hook-up.

Operating conditions

The BAC PF-64M series separator utilizes high centrifugal forces to separate solids from liquids. The suspended particle is simply dropped from the carrying fluid where it is collected for discard. The PF-64M separators do not require a backwashing and will not interrupt throughput when purging. Because no backwash is required large amounts of system fluids will not be wasted. The separator collects and concentrates particulate as it falls from the process fluid into the accumulation chamber. Because the separator and the accumulation chamber are at equal pressures, there is no need for any additional pressure to induce purging. Purging the accumulation chamber is done without excess waste of system fluid while the separator package remains "on-line".

Influent is fed via the pump tangentially into the separator acceptance chamber. The influent is spun in a downward motion pushing the suspended particulate to the walls of the separator vessel by centrifugal forces. Suspended solids are forced downward into the collection chamber for purge. The clean liquid then reverses direction moving upward entering the vortex finder where it is then returned back to the process system.

General maintenance procedures

Always follow the start-up and shut down procedures before and after any service or maintenance is done on the filter unit. The PF-64M series separators are designed for low maintenance and minimal service. With proper care the PF-64M series separators will provide trouble free service. The following is a list of maintenance check points and schedules.

 All recommendations are minimums. The environment/operating conditions in which the separator unit is installed will dictate the frequency of scheduled maintenance. Maintaining your PF-64M series separators will assure a long trouble free life.

1. Visually inspect separator every 48 hours (minimum) for proper operation (check for unusual noise and/or vibration).
2. Read pressure gauge (gauge reading should not exceed design pressure).
3. Purge separator as required (refer to "Purge Cycle" on page 1). Check for a build up of debris in accumulation chamber.
Run a manual purge cycle by switching the HOA switch to "Hand" position. Leave the purge valve open for a minimum of 5 seconds or until purge liquid becomes clear. Reposition the HOA switch to the "AUTO" position.
4. Clean pump pre-strainer (optional) before blind-off occurs (check as often as environment dictates).
5. Check condition of gaskets (optional pre-strainer) each time the separator is serviced.
6. Check voltage and amperage draw on motor lead.
7. The PF64M series separators are designed to operate within a specific flow range. Keeping the separator within the design flow range will produce optimal pressure drops and increase the separator efficiency. Running below the design flow rates will reduce efficiency while running above the design flow will increase wear (refer to Flow Rate vs. Pressure Loss chart).



Purge requirements

PF MODELS AND PURGE RATE

Model PF 64M	Purge Flow rate (in l/s)
64 M 012	1.6
64 M 015	1.6
64 M 020	1.6
64 M 025	1.6
64 M 030	1.6
64 M 040(A)	4.1
64 M 040 (B)	4.1
64 M 050	4.1
64 M 060	4.1



Purge flow rate is estimated at nominal pump pressure head and may vary by installation.

Setting Purge Timer

The purge time is set as follows:

- A - Purge Duration (purge valve open).
- B – Purge Off Interval (purge valve closed).

Once the HOA switch is placed into the "AUTO" position the timer initiates the purge off Interval (valve closed). Upon completion of the off interval time, the relay is energized and the purge duration begins. Once the purge open duration (valve open) is completed the purge valve will close. The cycle repeats until the HOA switch is turned "OFF" or "MANUAL" position. The Top two circles are for setting the purge valve open Duration. Upper circle is the time setting range selector. The duration can be turned for various times if needed. Lower circle is the % of this setting.

The lower two circles are for setting the interval between purge valve openings. The time setting range can be turned for various times if needed. Lower circle is the % of this setting.

Examples with factory setting:

- *Purge duration is set at 100 seconds and % at 30%:* the purge valve will open for 30 seconds (30% x 100 seconds)
- *Purge off interval is set at 10 hours and % at 60%:* the purge valve will open once every 6 hours (60% x 10 hours)

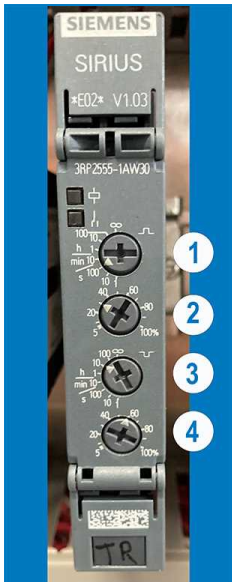

Purge timer

1. Duration scale (setting 100S)
2. Duration (setting 30% = 30 seconds)
3. Frequency/interval scale (setting 10 hours)
4. Frequency/interval (setting 60% = 6 hours)

Purge Cycle

The PF-64M series separators must be purged regularly as debris accumulates in the unit's collection chamber. If the purge chamber becomes full and is not purged the separator will no longer perform efficiently. During start-up the amount of purged solids generated by the separator may be high. It is recommended to adjust the purge time to allow 4 to 6 seconds of clear fluid prior to closing the purge valve. If the purge open timer has to be adjusted beyond 60 seconds to meet this recommendation, then more frequent purges (for example every 3 hours) may be required.

Several purge options can be utilized:

- **Manual purge** - purge valve is opened manually every time a purge cycle is required.
- **Continuous purge** - manual purge valve is throttled to maintain a constant purge.
- **Automatic purge** - automatic valve is installed to purge on a preset time cycle.

 The factory auto purge pre-set is 30 seconds every 6 hours.

It is imperative that the purge cycle lasts long enough to purge all solids from the collection chamber in order to extend the life of the purge valve. If the purge cycle does not last long enough, particulate can become wedged or pinched in the valve causing leaks or permanent damage to the valve.

Auto Purge Cycle

The purge cycle can be initiated either manually or by the purge cycle timer. The separator control cabinet is equipped with an Hand-Off-Auto (HOA) switch. The HOA switch allows for the automatic or manual purging of the separator. In the "HAND" position the purge valve will energize to an open (purge) position. In the "AUTO" position the cycle timer is energized and controls the purge time and frequency (refer to). The "OFF" position will disable the purge function in a closed position.

 Make sure that the purge valve actuator is positioned in the Auto mode to allow automatic operation.



Purge valve actuator position "AUTO"

Pump requirements

Optional Pump Pre-strainer

The pump pre-strainer housing is flanged mounted to the pump suction. The OPTIONAL pre-strainer contains a corrosion resistant basket with 3 mm perforations. The pre-strainer basket must be kept clean and free of debris. Always follow the shut down procedure before attempting any repairs, adjustments or cleaning. To clean the pre-strainer basket, loosen the four hex bolts that hold the cover in place. Gently lift the cover off the strainer body (take care not to damage the gasket). If the gasket does not come off in one piece, it will need to be replaced. Before replacing gasket, clean all surfaces of old material. Utilize the handle to remove the basket from the housing. After cleaning the basket, reverse the above procedure making sure that the gasket is in place and tighten the four hex bolts. Always follow the start-up procedures after any shut-down (See section "About Cold Weather Operation" on page 1).



Always relieve internal vessel pressure before attempting any repairs or adjustments on the filter unit.

Pump and Motor

The pump wet end is constructed with all bronze components, including the impeller, pump shaft, volute and jam nut. The close coupled pump and motor assembly is bolted together with four stainless steel hex bolts for ease of maintenance and repair. The pump utilizes a standard mechanical seal pressed into the motor bracket, which is bolted directly to the pump volute. The pump shaft slides over the motor shaft and is held in place with three set screws. The pump impeller is threaded on to the end of the motor shaft and locked in place with a hex jam nut (see to figure below).

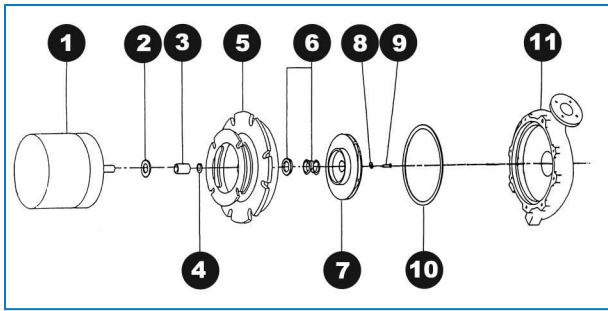

Pump and Motor PF-64M

1. Motor
2. Water slinger
3. Shaft sleeve spacer
4. Adapter
5. Mechanical seal
6. Impeller
7. Washer
8. Cap screw
9. Gasket, Case
10. Casing
11. Shaft sleeve

The nominal pump flows for the PF-64M series separators are indicated on the specific unit data sheet. The nominal flow is achieved at approximately 230 kPa discharge pressure.



CAUTION

Disconnect and lock out all electrical power to the filter prior to performing pump maintenance.

Cleaning and Adjusting Pump

Always follow the shut down procedure before attempting any repairs or adjustments. The impeller should spin freely. If not, check for an obstruction or debris that may be lodged between the impeller and volute or impeller and adapter bracket. If no debris can be found and the impeller remains obstructed, remove the bolts holding the volute to the motor bracket and the two bolts holding the motor to the base (see above Figure). Slide the motor and motor bracket away from the pump volute. Inspect the volute for foreign material. Reverse the above procedures to reassemble replace any gaskets that are not in good condition). Rotate the pump shaft manually after assembly to check clearance. Always follow the start-up procedures whenever the filter unit has been turned off.

PF-64M START-UP AND SHUTDOWN

Start-up

Before initial start-up or after a long shutdown period, the separator unit should be thoroughly inspected.



CAUTION

Perform the first five recommendations with the electrical power off and locked out. Refer to the section under "Safety" regarding the safeguarding of maintenance personnel from biological contaminants prior to start-up.

1. Close all isolation valves in interconnecting piping and relieve all pressure from the separator by opening the manual air relief valve.
2. Loosen the four hex bolts around the pump pre-strainer lid. Remove the lid, inspect gasket and lubricate if necessary. Clean debris from the pump pre-strainer basket. Prime the pump and associated piping by filling the pre-strainer housing. Replace the basket, and lid then tighten bolts.
3. Turn the pump and motor shaft by hand to insure free rotation.
4. Prime the pump by filling the pre-strainer and associated piping with water. Check the pump rotation by bumping the motor. Verify rotation with the arrow on the pump volute.
5. **Do not** run the pump for an extended period of time in reverse direction or dry. Have a qualified electrician change leads to correct rotation.
6. Open the service valves in the separator inlet, outlet, and purge lines. Before starting the pump, verify all valves are open. Open the manual air relief valve on top of the separator vessel. Start the pump and fill the separator. Once a steady stream of water is coming out of the manual air relief valve, and all air has been evacuated, the manual air relief valve can be closed.
7. Check the voltage and current of all leads on the pump motor. The correct amperage draw can be found on the motor nameplate.
8. Check the separator unit for any unusual noise or vibration. Shut separator unit off and contact your local BAC representative or the factory direct if there are any questions about the performance of the separator unit.
9. Check the separator unit and all integral piping to the unit for any air or fluid leaks. All air leaks must be found and repaired. Failure to do so could result in poor performance and/or personal injury.
10. Purge the separator (refer to "Purge requirements" on page 1).



Make sure that the purge valve actuator is positioned in the Auto mode to allow automatic operation.



Purge valve actuator position "AUTO"

11. After purging the separator, check the pressure gauges and record the start up differential pressure. Use the starting differential pressure as a bench mark whenever routine maintenance is performed. Pressure drop across the separator should be found between 27 tot 63 kPa.
12. After several hours of run time from start up, perform steps 8 through 12 again.



An excessive amount of air released from the vent valve can indicate an air leak. All leaks must be repaired before running the filter unit.

Shutdown

The following services should be performed when the unit is to be shutdown for a prolonged time period.

1. Run the separator unit through a complete purge cycle.
2. Close the service valves in the separator inlet and outlet lines.
3. Relieve all pressure from the separator vessel and piping. Open the manual relief valve, located on top of the vessel and leave the valve open.
4. Open the purge valve. Allow the vessel to drain fully. Once the separator is empty close the purge valve and manual air relief valve.
5. Shut off and lock out all electrical power.
6. Drain all external piping to and from the separator.
7. Remove the bolts from the pump pre-strainer cover. Remove the cover, and clean debris from the pump pre-strainer basket. Inspect the gasket and lubricate (replace gasket if necessary). Replace the basket and cover and tighten bolts.



PF-64M

COLD WEATHER OPERATIONS

About cold weather operation

When the PF-64M series separator is exposed to below-freezing temperatures, it will require protection to prevent freezing. An indoor installation in a heated room is the best way to preventing freezing of any liquid in the separator unit. If an indoor installation is not practical, supplemental heat must be supplied. Heat tape and insulation around the liquid filled filter components (and all piping that remains filled with water at filter shut down) must be used to prevent freezing. The separator unit should be drained when not in use for long periods of time. Refer to shutdown procedures below.



PF-64M

COMPREHENSIVE MAINTENANCE

About comprehensive maintenance

BAC maintains a complete stock of replacement parts. When ordering replacement or stock parts, be sure to include the unit serial and model numbers.

The following spare parts are recommended:

1. Pump seal and gasket kit.
2. Pre-strainer gasket. (optional)
3. Bleed valve and actuator assembly
4. Replacement pump.
5. Inlet/outlet gauges set.

About fluid treatment

Filtration is an effective way of reducing the level of suspended solids in a system. However, it is only one portion of a complete treatment program. Dissolved solids will not be removed from the system by media filtration. It is important to realize that the dissolved solids will concentrate, and can cause damage to a system. Furthermore, airborne impurities and biological contaminants may be introduced into the system through the equipment being filtered.

Biological control

The growth of algae, slimes and other micro-organisms, if uncontrolled, will reduce system efficiency and may contribute to the growth of potentially harmful micro-organisms, such as Legionella, in the recirculating water system.

Accordingly a treatment programme specifically designed to address biological control should be initiated when the system is first filled with water and administered on a regular base thereafter in accordance with any regulations (national, regional) that may exist or in accordance with accepted codes of good practice, such as EUROVENT 9-5/6, VDMA Detailsheet 24649 etc.

It is strongly recommended to monitor the bacteriological contamination of the recirculating water on a regular base (for example, TAB test with dip slides on a weekly base) and record all results.

Chemical treatment

1. The chemicals must be compatible with the materials of construction used in the cooling system.
2. Chemicals should be fed into the re-circulated water to avoid localised high concentrations, which may cause corrosion. Chemicals are normally fed into the pump discharge line. Batch feeding of chemicals does not afford adequate control of water quality and is not recommended.

To control all potential contaminants, a chemical treatment program must be employed by a competent professional. Such treatment should be initiated before the system start-up and continued regularly thereafter.

The service expert for BAC equipment

We offer tailored services and solution for BAC cooling towers and equipment.

- Original spare parts and fill -for an efficient, safe and year round reliable operation.
- Service solutions - preventive maintenance, repairs, refurbishments, cleaning and disinfection for reliable trouble-free operation.
- Upgrades and new technologies - save up energy and improve maintenance by upgrading your system.
- Water treatment solutions - equipment for controlling corrosion scaling and proliferation of bacteria.

For more details, contact your local BAC representative for further information and specific assistance at www.BACservice.eu

More information

REFERENCE LITERATURE

- Eurovent 9-5 (6) Recommended Code of Practice to keep your Cooling System efficient and safe. Eurovent/Cecomaf, 2002, 30p.
- Guide des Bonnes Pratiques, Legionella et Tours Aéroréfrigérantes. Ministères de l'Emploi et de la Solidarité, Ministère de l'Economie des Finances et de l'Industrie, Ministère de l'Environnement, Juin 2001, 54p.
- Voorkom Legionellose. Ministerie van de Vlaamse Gemeenschap. December 2002, 77p.
- Legionnaires' Disease. The Control of Legionella Bacteria in Water Systems. Health & Safety Commission. 2000, 62p.
- Hygienische Anforderungen an raumluftechnische Anlagen. VDI 6022.

INTERESTING WEBSITES

Baltimore Aircoil Company	www.BaltimoreAircoil.com
BAC Service website	www.BACservice.eu
Eurovent	www.eurovent-certification.com
European Working Group on Legionella Infections (EWGLI)	EWGLI
ASHRAE	www.ashrae.org
Uniclimate	www.uniclimate.fr
Association des Ingénieurs et techniciens en Climatique, Ventilation et Froid	www.aicvf.org
Health and Safety Executive	www.hse.gov.uk

ORIGINAL DOCUMENTATION



This manual is originally made in English. Translations are provided for your convenience. In the event of discrepancies, the English original text shall prevail over the translation.



A series of horizontal dotted lines for writing, spanning the width of the page.



A series of horizontal dotted lines for writing, spanning the width of the page.



A series of horizontal dotted lines spanning the width of the page, providing a template for writing or drawing.





A series of horizontal dotted lines for writing, spanning the width of the page.

COOLING TOWERS

CLOSED CIRCUIT COOLING TOWERS

ICE THERMAL STORAGE

EVAPORATIVE CONDENSERS

HYBRID PRODUCTS

PARTS, EQUIPMENTS & SERVICES

BLUE by nature
GREEN at heart



www.BaltimoreAircoil.com

Europe@BaltimoreAircoil.com

Please refer to our website for local contact details.

Industriepark - Zone A, B-2220 Heist-op-den-Berg, Belgium

© Baltimore Aircoil International nv